

EBONY



CRIOCABIN
TASTE PRESERVATION

▶ ESSENZIALITÀ PER UN ALTA VISIBILITÀ

Grande visibilità dei prodotti esposti grazie alle superfici piane che riducono al minimo riflessi e rifrazione.

▶ ESSENTIALITY FOR HIGH VISIBILITY

Great visibility of displayed products thanks to flat surfaces reducing reflections to the minimum.

▶ ESSENTIALITE POUR UNE GRANDE VISIBILITÉ

Grande visibilité des produits exposés grâce aux surfaces plates qui réduisent au minimum les reflets.

▶ WESENTLICHKEIT FÜR GROSSE SICHTBARKEIT

Große Sichtbarkeit der ausgelegten Produkte dank der flachen Flächen, die die Abspiegelung minimal reduzieren.





SPECIAL DESIGN CRIOCABIN STUDIO



Cor-Ten Steel











P30

P29





SPECIAL DESIGN CRIOCABIN STUDIO



Slats - Golden Wood

- ▶ Portacarta multifunzione su richiesta
- ▶ Multifunctional paper holder on request
- ▶ Porte-papier aux plusieurs fonctions sur demande
- ▶ Mehrzweckpapierhalter auf Wunsch









P31 matt



P01



W152

I301





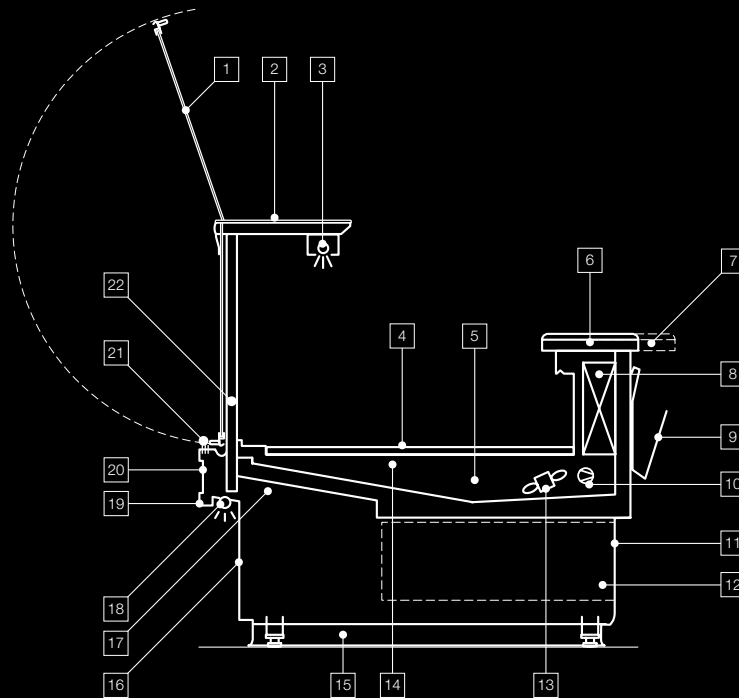

CARATTERISTICHE DEL MOBILE

1. Vetro apribile verso l'alto a pistoni.
2. Piano d'appoggio superiore fisso in vetro da 36 cm.
3. Illuminazione: tubo fluorescente con luce rosa Osram 76. (p)
4. Piano d'esposizione in acciaio inox AISI 304. (p)
5. Vasca senza componenti frigoriferi per garantire la massima pulizia.
6. Ebony A: piano di lavoro in acciaio inox AISI 304 antigraffio.
Ebony D: piano di lavoro rivestito in Corian. (p)
7. Piano di lavoro da 36 cm con portacarta grande. *
8. Evaporatore trattato in cataforesi.
9. Portacarta. (p)
10. Valvola termostatica a refrigerazione R404a. (p)
11. Chiusura posteriore con pannello in lamiera plastificata.
12. Ripiano posteriore sottovasca. *
13. Refrigerazione ventilata con potenziometro per regolazione della portata.
14. Interno del mobile in acciaio inox AISI 304.
15. Zoccolo parapolvere su tutto il perimetro del banco.
16. Pannello frontale personalizzabile. (p)
17. Canalizzabile.
18. Illuminazione frontale. *
19. Cornice frontale in alluminio lucido. (p)
20. Inserto cornice frontale personalizzabile - vedi tabella colori. (p)
21. Ventilazione frontale antiappannante.
22. Angoli a spigolo e/o sferici 90°-45°-22,5° a seconda delle versioni.

CABINET FEATURE

1. Lift-up glass.
2. Fixed 36 cm glass top surface.
3. Lighting: fluorescent tube with rose light Osram 76. (p)
4. AISI 304 stainless steel display surface. (p)
5. Tank without freezing components to allow maximum cleaning.
6. Ebony A: working board in stainless steel scratchproof.
Ebony D: working bench with upper covering in Corian. (p)
7. Working Board 36 cm with compartment paper holder, "comfort" type. *
8. Evaporator handled with cataphoresis.
9. Paper holder. (p)
10. R404a thermostatic refrigeration valve. (p)
11. Back panel in plastic-coated iron sheet.
12. Lower back storage. *
13. Ventilated refrigeration with potentiometer to adjust air flow rate.
14. AISI 304 stainless-steel unit interior.
15. Perimetrical bumper skirting.
16. Personalized front panel - see colour chart. (p)
17. Multiplexable.
18. Front lighting. *
19. Front frame in aluminium with polished finishing. (p)
20. Customizable frame insert - see colour chart. (p)
21. Anti-fogging front ventilation.
22. Angular corners and/or spherical corners 90°-45°-22,5° depending on the versions.

CARACTERISTIQUES DE LA VITRINE

1. Vitre relevable.
2. Plan d'appui supérieur fixe en verre de 36 cm.
3. Éclairage: tube fluoréscent avec lumière rose Osram 76. (p)
4. Plan d'exposition en acier AISI 304. (p)
5. Cuve sans composantes frigorifiques afin de garantir le nettoyage maximum.
6. Ebony A: tablette de travail en acier inox AISI 304 anti-rayure.
Ebony D: tablette de travail avec revêtement supérieur en Corian. (p)
7. Tablette de travail de 36 cm avec porte papier du type "comfort". *
8. Évaporateur traité à la cataphorese.
9. Porte-papier. (p)
10. Soupape thermostatique à réfrigération R404a. (p)
11. Panneau arrière en tôle plastifiée.
12. Réserve derrière sous cuve. *
13. Réfrigération ventilée avec potentiomètre pour régulation du débit d'air.
14. Intérieur de la vitrine en acier inox AISI 304.
15. Plinthe de sol périmétral.
16. Panneau frontal personnalisable. (p)
17. Canalisable.
18. Éclairage frontal. *
19. Décor frontal en aluminium finition polie. (p)
20. Décor intérieur de la corniche personnalisable - voir tableau des couleurs. (p)
21. Ventilation frontale antibuée.
22. Coins anguleux et/ou sphériques 90°-45°-22,5° suivant les versions.

EIGENSCHAFTEN DES MÖBELS

1. Hebeglasscheibe.
2. Fix montierte, obere Ablage aus Glas, Breite: 36 cm.
3. Beleuchtung: Leuchtrohr mit rosa Lichtern Osram 76. (p)
4. Auslegfläche aus Edelstahl AISI 304. (p)
5. Wanne ohne Kühlbestandteile um maximale Reinigung zu garantieren.
6. Ebony A: Arbeitsplatte aus kratzfestem Edelstahl AISI 304.
Ebony D: Arbeitsplatte mit Oberverkleidung aus Corian. (p)
7. Arbeitsbrett Ausführung, 36 cm mit Papierfach mit 1 Taschen vom Typ "comfort". *
8. Verdampfer mit Kataforesi.
9. Papierfach. (p)
10. Thermostatventil mit Kühlung R404a. (p)
11. Rückwandverkleidung in plastifiziertem Blech.
12. Ungekühlter Abstellraum auf Bedienseite. *
13. Durchlüftete Kühlung mit Potentiometer für die Einstellung der Luftmenge.
14. Innenverarbeitung des Möbels aus rostfreiem Edelstahl AISI 304.
15. Umlaufende Wischleiste.
16. Individuell gestaltbares Frontpaneel. (p)
17. Zusammenbaubar.
18. Frontbeleuchtung. *
19. Frontrahmen aus Aluminium mit polierter Verfeinerung. (p)
20. Einsatz auf dem Frontrahmen - siehe Farbtabelle. (p)
21. Antitbeschlag Frontumluftkühlung.
22. Scharfkantiger Winkel und/oder Kugelwinkel 90°-45°-22,5° je nach Ausführung.

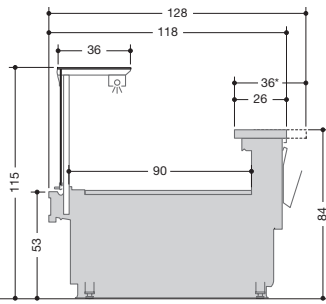

EBONY A

Piano di lavoro in acciaio inox antigraffio.
 Angoli a spigolo; su richiesta eseguibili con qualsiasi gradazione.
 Angular corners; on demand any corner degree is possible.
 Working board in stainless steel scratchproof.
 Coins anguleux; sur demande tout degré d'inclinaison possible.
 Tablette de travail en acier inox anti-rayure.
 Eckige Winkel; auf Wunsch mit jedem Winkelgrad erhältlich.
 Arbeitsplatte aus kratzfestem Edelstahl 304.

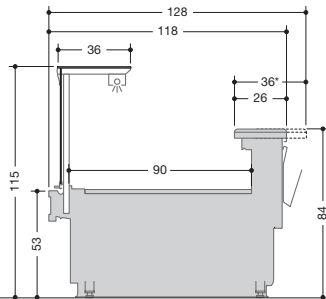

EBONY D

Piano di lavoro rivestito superiormente in Corian.
 Angoli sferici 90°-45°-22,5° aperti e chiusi.
 Working bench with upper covering in Corian.
 Spherical corners 90°-45°-22,5° internal and external.
 Tablette de travail avec revêtement supérieur en Corian.
 Angles sphériques 90°-45°-22,5° fermé et ouvert.
 Arbeitsplatte mit Oberverkleidung aus Corian.
 Abgerundete Winkel 90°-45°-22,5° aussen und innen.

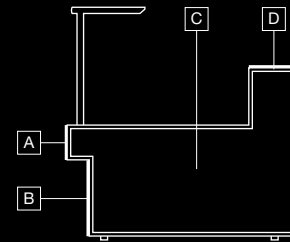

A	B	C	D
P01			Ebony A
P02		P01★	
P23		P02★	
P24		P23★	
P25	P01	P24★	
P26	P02	P25★	
P27★	P23	P26★	
P28★	P24	P27★	
P29★	P25	P28★	
P30★	P26	P29★	
P31	P27★	P30★	Ebony D
P32	P28★	P31★	
P33★	P29★	P32★	
P34★	P30★	P33★	
P35★	P31	P34★	
P91	P32	P35★	
P94	P33★	P91	
P95	P34★	I301★	
I301	P35★	I302★	
I302★	P91	I303★	
I303★	P94	I301★	
W101★	P95	I303★	
W102★	I301	W101★	
W103★	I302★	W102★	
W151★	I303★	W103★	
W152★	W101★	W151★	
L501★	W102★	W152★	
L502★	W103★	W160★	
L503★	W151★	W170★	
L504★	W152★		
L505★			
C81★			

P = Lamiera
 W = Legno
 K = Corian
 L = Ecopelle
 ★ Colore con sovrapprezzo

Si eseguono personalizzazioni e colori speciali su richiesta del cliente.

P = Plate
 W = Wood
 K = Corian
 L = Faux Leather
 ★ Color at extra cost

We make custom and special colors on request.

P = Plaque
 W = Bois
 K = Corian
 L = Faux cuir
 ★ Supplément couleur

Nous faisons des couleurs personnalisées et sur demande spéciale.

P = Tafel
 W = Holz
 K = Corian
 L = Kunstleder
 ★ Farbzuschlag

Wir machen individuelle und Sonderfarben auf Anfrage.



I colori RAL sono disponibili anche in versione opaca (matt).

A causa delle tecniche di riproduzione e di stampa, i colori possono essere diversi da come sono presentati. I colori RAL possono subire leggere variazioni cromatiche.

RAL colours are also available with a matt finish (matt).

Due to printing and reproduction techniques, the colours could be different to how they are represented. The RAL colours can suffer slight chromatic variations.

Les couleurs RAL sont aussi disponibles en version opaque (matt).

A cause des techniques de reproduction et d'imprimerie, les couleurs peuvent être différentes de comme ils sont présentées. Les couleurs RAL peuvent subir de légères variations chromatiques.

Die RAL-Farben sind auch in der matten Version lieferbar.

Die Farben können wegen Druck- und Reproduktionstechnik anders sein als die, die im Prospekt angegeben sind. RAL Farben können leichte farblichen Veränderungen erleide.

03-13/2000 - pellino.it

Le caratteristiche tecniche potranno subire modifiche senza preavviso - Technical details could be changed without notice
Les caractéristiques techniques pourraient subir des modifications sans préavis - Änderungen vorbehalten



CRIOCABIN SpA | 35033 Praglia di Teolo - Padova (Italy)
Z.I. Selve - Via S. Benedetto, 40/A

| Tel. +39 049 9909100
| Fax +39 049 9909200

| www.criocabin.com
| sales@criocabin.com